

# 23869

# Eldon

## Master Engine Timing Tool Set | 2009

Renault | 2 of 2



### Description

This Master set of engine timing locking tools has been updated to include applications for the latest Renault DCi engines.

The items highlighted represent the additions to the original master kit and can be found in the second metal case.

This master timing tool kit has been specifically compiled to give a comprehensive range of engine timing locking tools for Cam belts, chains and gears.

### Packaging

Metal Tin and Label

### Additional Information

22 December 2009



**T** TOOL  
CONNECTION

Distributed by The Tool Connection Ltd.  
Kineton Road | Southam | Warwickshire | CV47 0DR  
T | +44 (0) 1926 815 000 F | +44 (0) 1926 815 888  
E | info@toolconnection.co.uk www.toolconnection.co.uk

**LASER**

**Kamasa**

**Gunson**

**Eldon**

Layout ID	Eldon Component	OEM Ref	Description
A	23054-04	MOT 1489	Crankshaft Locking Pin
B	23061-08		HT Setscrew M6 x 45
C	23061-09		HT Setscrew M8 x 80
D	23069-21	MOT910	Locking Pin
E	23069-22	MOT910	Locking Pin
F	23069-23	MOT861/1863	Locking Pin
G	23069-24	MOT1318	Locking Pin
H	23069-41	MOT1340	Crankshaft TDC Timing Pin
I	23069-42	MOT1135-01	Tensioner Spanner
J	23069-43	MOT1386	Tensioning Tool
K	23069-45	MOT1348	Tensioning Tool
L	23069-47	MOT1337	Camshaft Setting Tool
M	23069-48	MOT1312	Tensioning Tool
N	23069-52	MOT1496	Camshaft Setting Tool
O	23069-56	MOT1384	Tensioning Tool
P	23069-58	MOT1490-01	Camshaft Pulley Alignment Tool

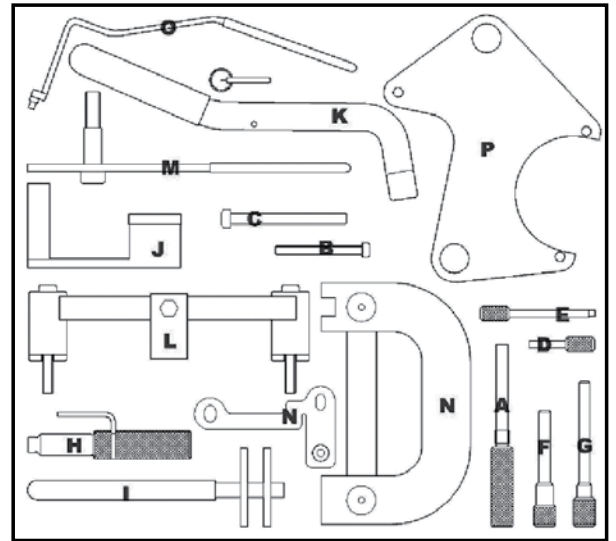

Layout ID	Eldon Component	OEM Ref	Description
Q	23164-17	MOT1538	Hi-Pressure Pump Pin Assy.
R	23164-18	MOT1536	Crankshaft Timing Pin
S	23164-19	MOT1537	Exhaust Camshaft Setting Tool
T	23164-20	MOT1534	Inlet Camshaft Setting Tool
U	23069-25	MOT1430	Locking Pin
V	23069-59	MOT1543	Pre-Tensioning Tool
W	23069-59H	MOT1705	Cover Nr.4
X	23069-21	MOT1526	Camshaft Alignment Tool
Y	23069-71	MOT1801	Camshaft Sprocket Lock
Z	23061-16	MOT1200-01	Inj. Pump Sprocket Lock

